

• Additional filtration stage

For special and severe applications (smoke, VOC and odors), it is effective to install an additional filtration module to remove further pollutants.

• 另外的過濾組

如應用於特別嚴苛的環境(煙霧、揮發性有機化合物和氣味等)·本機可加裝另外的過濾設備·可有效對汙染物做進一步過濾。

Absolute filtration

To solve specific problems (fumes), an additional filter module can be installed. **Absolute** with HEPA filtering levels up to H 13 - 99.95 MPPS according to EN 1822.

Besides, the clogging can be monitored with an optional pressure gauge.

絕對過濾

如需解決特殊問題(如煙霧)可另外加裝模組·根據歐規EN1822標準測試·高效濾網HEPA過濾層級可達99.95% MPPS(相當於H13)·另外·堵塞狀況可經由選配的壓力計監測。

Maintenance time alarm signal

維修時間警告訊號

Additional controls and monitoring systems

額外控制和監視系統

Vertical stands, stand on wheels

附輪直立式支架

Accessories for installation

The WS 2 series has a complete line of dedicated accessories for installation on the machine tools.

裝機附件

WS 2系列擁有安裝於工具機上完整的相關附件產品線

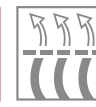

• Bar Feeding Systems
• 棒材送料系統

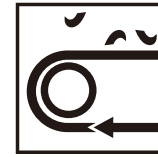

• Chip Management Systems
• 切屑管理系統



• Coolant Management Systems
• 冷卻液管理系統

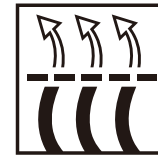

• Air Filtration Systems
• 空氣濾清系統

Your "One-Stop-Shop" for machine-tool peripherals

LNS provides a full range of bar feeders, chip conveyors, coolant management systems and air filtration systems which is second to none on the market. We are known in the industry for the solid expertise we have gained over several decades in an exceptionally wide range of applications, our excellent customer service and our sound technical support. This support is ensured by highly qualified technicians who are available at key locations throughout Asia.

“一站式”服務，滿足您一次購足工具機週邊配備之需求

艾恩司提供您完整的工具機週邊產品，包括棒材送料機、切屑與冷卻液管理系統及空氣濾清系統，所有配備可謂市場上首屈一指的優良產品。艾恩司擁有多年的客戶服務經驗與技術支援團隊，除了提供齊全的設備零件更換，技術人員皆受過專業訓練，派及亞洲各區，給予顧客最完善的售後服務，是您值得信賴的最佳夥伴。



LNS Taiwan Co., Ltd. 台灣艾恩司股份有限公司
No. 133, Lane 418, Sec. 3, Xinan Rd., Wuri
District, Taichung City 41469, Taiwan
41469 台灣台中市烏日區溪南路三段418巷133號

Tel: +886-4-2335-4920 sales@LNS-asia.com
Fax: +886-4-2335-2056 www.LNS-asia.com



www.LNS-asia.com

FOX WS 2

Oil mist collectors

油霧收集器

Fox WS 2 Series: 500 • 1000 • 1500 • 2000



LNS Taiwan Co., Ltd. / 台灣艾恩司股份有限公司
Taichung City 41469, Taiwan / 41469 台灣台中市
www.LNS-asia.com



FOX WS 2

• Oil mist collectors

The Fox WS 2 series represents a quality solution for the collection of soluble coolant and oil mist. It is characterized by a sophisticated design, compact dimensions, standard and customizable accessories, and 4 sizes ranging from 500 to 2000 m³/hr.

Specifically developed for the elimination of mist and smoke of wet machining operations. These mechanical filters can also be employed in mixed application (wet/dry) and for EDM machines.

• 油霧收集器

Fox WS 2系列產品提供了回收水溶性冷卻液和油霧收集的解決方案。其特色包含了精密的設計、簡潔的結構、標準及客製化的零配件，500到2000 m³/hr四種不同排風量產品。

專為減少濕式加工過程所產生的油霧、蒸氣而發展出的機械式過濾器，甚至可應用於乾/濕混合及放電加工機的使用場合。

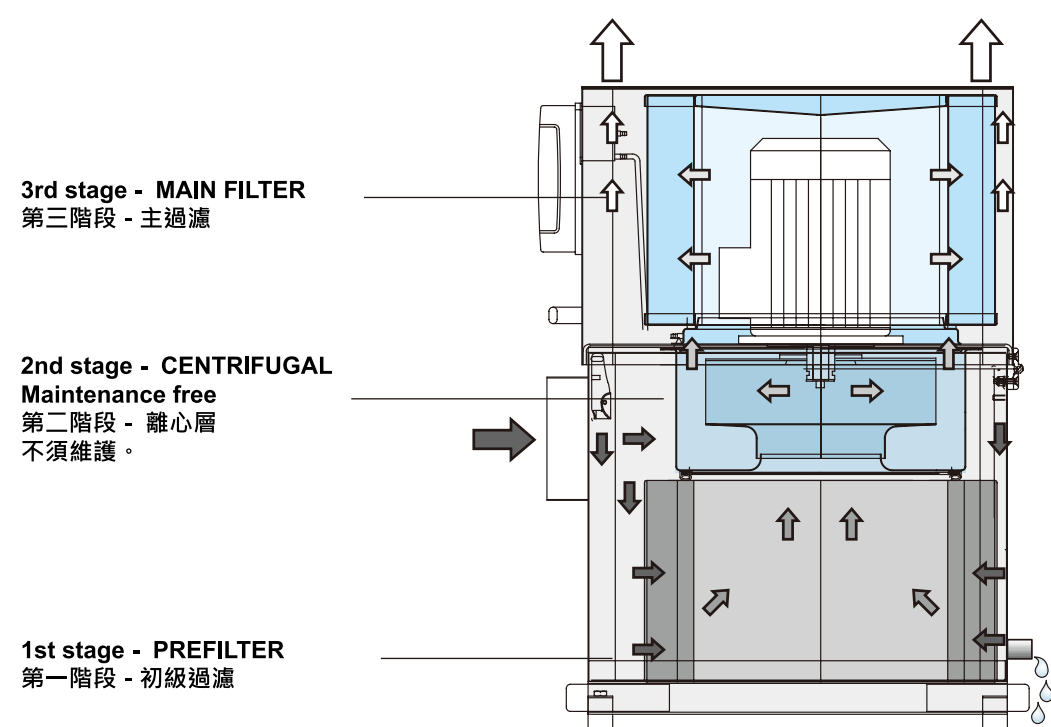
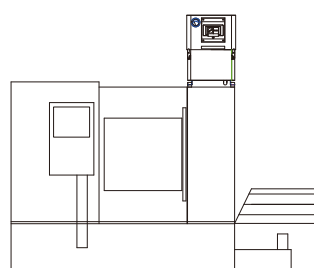

• Guaranteed filtration

1st STAGE - PREFILTER: Made up by three or two progressive filter sectors according to the model, ensures excellent solid pollution accumulation and liquid drainage capacity. The first prefilter media in metal screen is totally recyclable (only for emulsion version).

2nd STAGE - CENTRIFUGAL FILTRATION: a special impeller ensures the centrifugal effect that enables the continuous evacuation of collected particles.

3rd STAGE - MAIN CARTRIDGE FILTER: Made up of glass microfibre and polyester filtering sectors. The final stage provides an average overall efficiency level higher than 99% (measured according to standard AFNOR NFX44-060).

OPTIONAL - PRE-PREFILTER: Made up by one or two flat filter, as a "pre-prefilter", this optional filter ensures high level blocking of macromolecular substance, and prolong the product lifecycle. Special designed three types filter media apply to different kinds of pollution.

• 過濾保證

第一階段 - 初級過濾: 根據不同機型由三個或兩個漸進式過濾組組成，確保具有聚集固態汙染物的優秀效能與排液效果；第一層金屬濾網可回收(只適用於水溶性過濾機型)。

第二階段 - 離心分離層: 搭配特殊葉輪確保離心作用，持續排出收集粒子。

第三階段 - 主過濾層: 由多層玻璃纖維和聚酯過濾組成，整體平均過濾效率可達99%(根據AFNOR NFX44-060標準驗證)。

選配 - 金屬前置過濾盒: 由一或兩片金屬過濾網組成，作為前置過濾，在初始過濾階段即可有效阻擋大分子汙染物，延長設備生命週期；特別設計三種過濾材質，使用者可依不同待過濾物質選擇合適濾網。

• Services

LNS Fox's entry in the market is not limited to the supply of filtration units but, upon request, to a complete consulting service related to the evaluation of the air quality in the workplace.

With the support of internal qualified personnel we can perform an analysis of pollutants concentration level and in conjunction with a certified external lab we submit a complete report of evaluation. This certifies the filtration efficiency that is obtained once the unit is installed on site.

• 服務

艾恩司Fox系列在市場中不僅提供過濾器等設備，更能針對工作場所中的空氣品質進行評估，進而根據需求提供完整的對策服務。在艾恩司內部專業人員的支援下，我們可以針對汙染濃度等級進行分析，並與外部實驗室合作，提出最完整的評估報告。過濾效率在安裝過濾器後即可獲得實證。



• Filtration efficiency / Air quality

The filtration efficiency of the OIL MIST COLLECTOR determines how clean the air is inside the workshop and how healthy is the environment for the operator. LNS provides test reports to certify the filtration level of the Fox WS 2 line according to the AFNOR norm. In addition, trained LNS technicians can provide onsite measurement of air quality to measure with high accuracy how clean the air is. The analysis is conducted using a sophisticated dedicated instrument.

• 過濾效率 / 空氣質量

油霧收集器的過濾效率決定了工作場所的空氣清潔程度和環境健康指數。艾恩司符合AFNOR國際規範，提供測試報告證明WS 2系列油霧收集產品的過濾等級；此外，我們有經培訓認證的技術人員使用專業的精密檢測儀器，可提供現場空氣檢測的服務。



• Technical specifications 技術規格

Model 型號	WS 2 500		WS 2 1000		WS 2 1500		WS 2 2000	
Frequency 電頻率 [Hz]	50	60	50	60	50	60	50	60
Air flow** 空氣流量** [m ³ /h]	470	560	950	1130	1450	1720	1800	2120
Static pressure 靜壓 [Pa]	610	890	950	1420	1260	1800	1720	2300
Sound level 噪音等級 [dB(A)]	65	67	71	73	74	76	76	78
R.P.M. 轉速 [Kw]	2790	3350	2850	3420	2855	3425	2855	3425
Weight 重量 [kg]	35		55		75		85	

** WS 2 500-1000-1500-2000: With HEPA filter installed about -15%

** 加裝HEPA濾器，排風量減少約15%。

- Information is subject to change without notice. 本公司保留變更權利不另行通知。
- For the best efficiency, suggest that the filter type should be changed in accordance with the application. 濾心規格依應用可能須進行調整以達最佳效率。
- Electrical motors (V/Hz) 馬達規格 (電壓/頻率) 200-220-230-380-400-460V/50-60Hz



• Dimensions (mm) 尺寸 (mm)

Model 型號	A	B	C	D	E	ø F	ø G	H	I	L	N1 x N2 x øM
Fox WS 2 500	408	515	652	460	276	124	25	67	450	120	363 X 395 X 9
Fox WS 2 1000	525	600	801	543	362	149	25	60	567	135	478 X 478 X 9
Fox WS 2 1500	600	673	908	617	396	198	25	59	640	176	552 X 552 X 9
Fox WS 2 2000	663	737	994	680	437	198	25	59	703	181	615 X 615 X 9

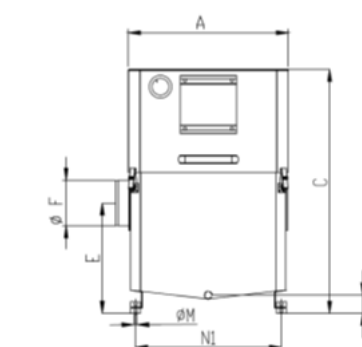

• Air flow 空氣流量

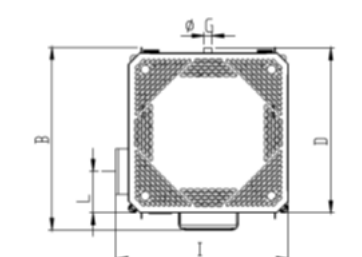
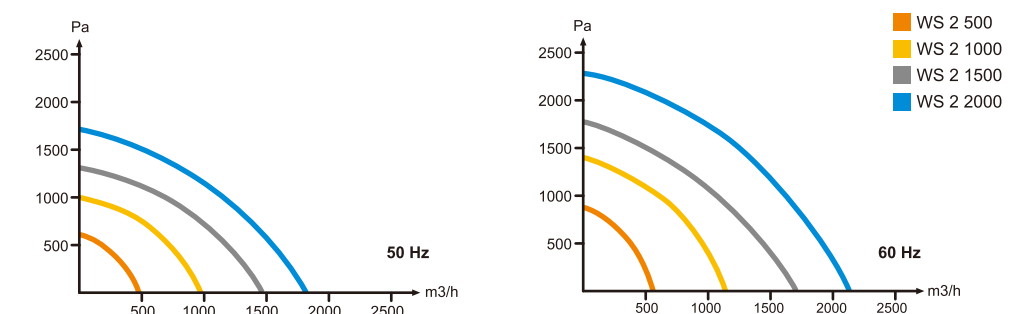

• Easy maintenance

Maintenance requires less than five minutes (complete replacement of filters). The result is a considerable saving in time and costs across the life of the unit.

• 維護簡易

維護時間不超過5分鐘(全部濾芯更換)；使用本機可達到節省時間及成本的雙重效果。

• Guaranteed reliability

Ensuring the high quality, each components and the special impeller are subjected to select and test thoroughly.

• 可信賴保證

為確保優良品質，每一個零件及特殊渦輪葉片都經過嚴密的全檢及測試。

• Patented system 專利系統

