

# KT-12, 15, 16, 20, Loading Magazines Bar Feeder

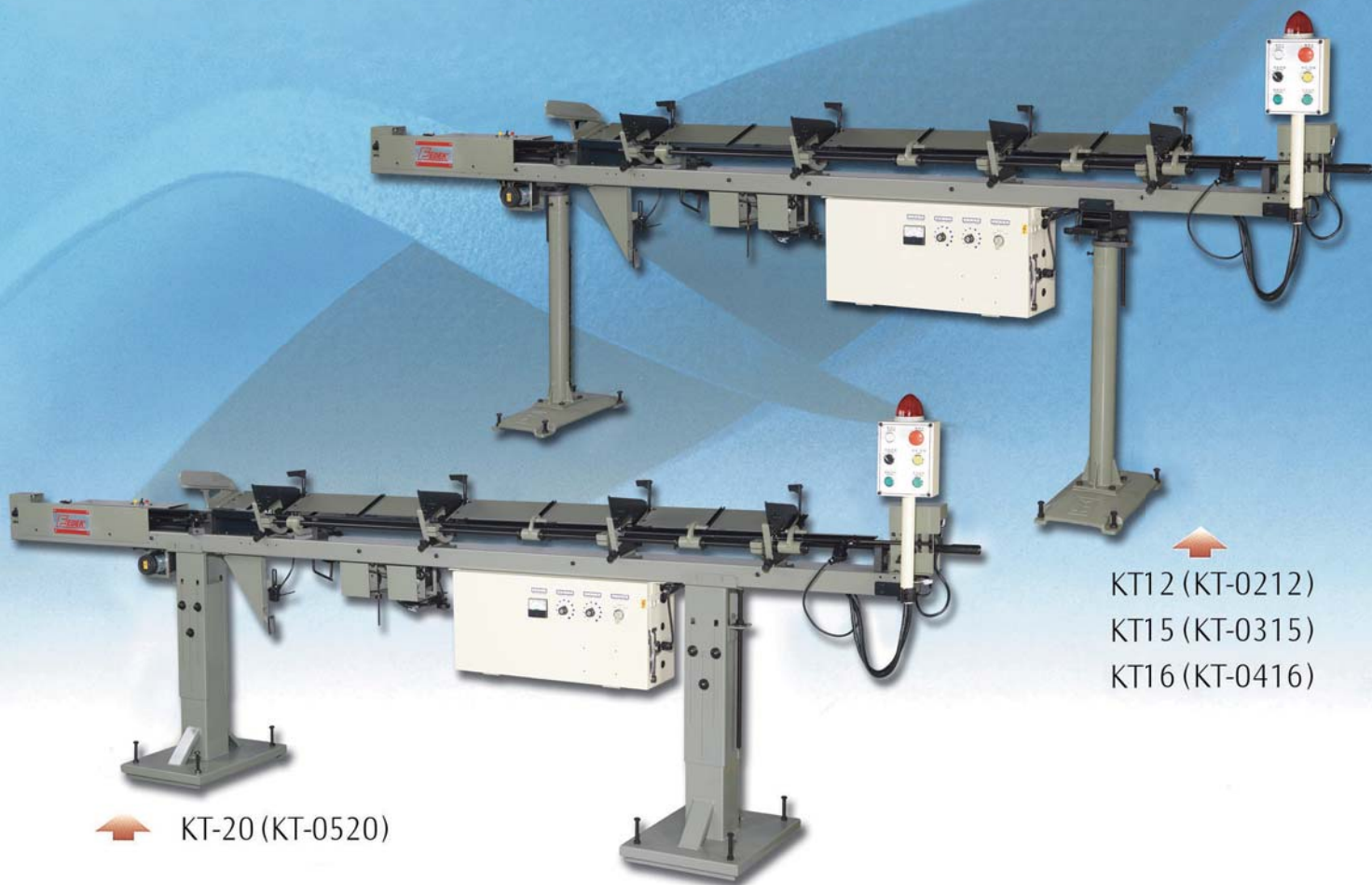

KT12 (KT-0212)  
KT15 (KT-0315)  
KT16 (KT-0416)

KT-20 (KT-0520)

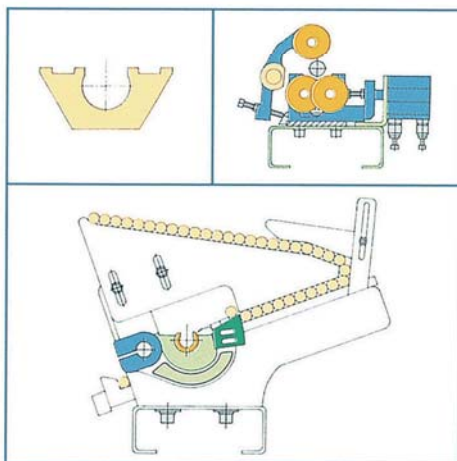

- 雙層置料設計，大幅增加棒材容量。
- 採用伺服馬達傳動，配合平衡力矩，送料效果優異。
- 移動式腳座，機體固定快速、方便。
- 氣壓式防震裝置，結構簡化、安全耐用（選購配備）。
- 膠管防傷裝置，有效減震，降低噪音（選購配備）。
- 同步裝置（選購配備）。
- Double-layer magazine greatly increases bar loading capacity.
- Servo motor drive combined with balanced torque creates superior bar feeding performance.
- Movable stand ensures fast, convenient mounting of the feeder.
- Air operated anti-vibration device is simplified in structure, safe and durable. (Optional)
- Rubber hose anti-scratch device reduces machine vibration and noise to a minimum. (Optional)
- Synchronized device. (Optional)

Model機型	KT-12 KT-0212	KT-15 KT-0315	KT-16 KT-0416	KT-20 KT-0520
Materuak duaneter材料直徑	Ø2 ~12mm	Ø3~15mm	Ø4~16mm	Ø5~20mm
Loading capacity 材料收容量	Ø12mm x 34 pcs	Ø15mm x 28 pieces	Ø16mm x 26 pieces	Ø20mm x 20 pieces
Length of Material材料長度	Type 2.5 2580mm , Type 3.0 3080mm			
Length of Machinery長X寬	Type 2.5 3800 x 480mm , Type 3.0 4300 x 480 mm			
The air Pressure being Used使用壓力	5kg / cm <sup>2</sup> ~ 7kg / cm <sup>2</sup>			

# KE-408 / KE-710

## Small Bar Magazine Bar Feeder



- 螺桿式下料每轉一圈一支下料。
- 小直徑料管，小間隙料蓋。
- 雙夾料設計，確保夾料中心精準。
- 重錘式送料機構，適合細棒材。
- 採用鋼索傳動，送料輕巧。
- 耐高轉速12000RPM。
- 排料機構簡化，材料無彎曲之慮。

- Screw type bar unloader allows one piece unloading per revolution.
- Small diameter tube. Tight bar guard.
- Double material clamps ensure accurate center of clamping.
- Heavy weight feed mechanism suits slender materials.
- Steel wire transmission for effortless and smooth feeding.
- High running speed up to 12000 RPM.
- Simplified bar arrangement eliminates bar bending problem.

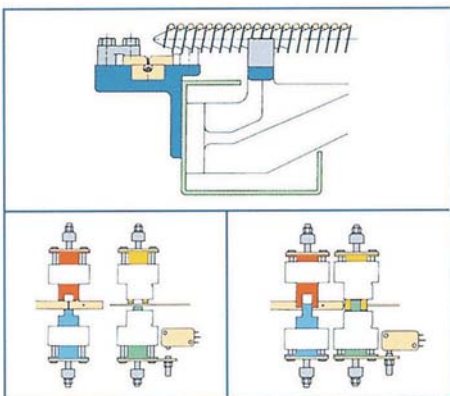

MODEL 機型	KE-408	KE-710
Diameter of material 材料直徑	Ø0.8 ~ Ø4 mm	Ø1 ~ Ø7 mm
Length of material 材料長度	1.5M / 2.0M / 2.5M / 3.0M	
Material loading capacity 材料收容量	40 pcs	22 pcs
Power supply 電源供應	220V 2p (Adjustable upon power supply from lathe 可依車床供電調整)	
Weight 重量	156 ~ 210 kg	

- 本公司不斷研究創新，尺寸規格如變更，恕不另行通知。
- Design and specifications are subject to change without prior notice.



LNS Taiwan Co., Ltd. 台灣艾恩司股份有限公司  
No.133, Lane 418, Sec. 3, Xinan Rd., Wuri  
District, Taichung City 41469, Taiwan  
41469 台灣台中市烏日區溪南路三段418巷133號

Tel: +886-4-2335-4920 sales@LNS-asia.com  
Fax: +886-4-2335-2056 www.LNS-asia.com