

Precision Machinery Vice

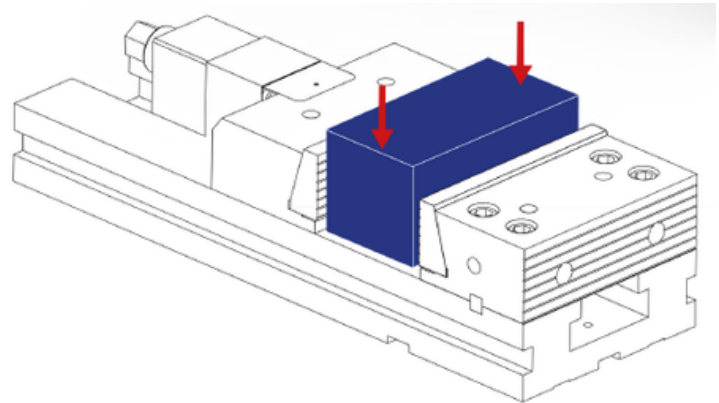

Order Code	Dimensions						Max. Gripping Force (kn)	Weight (kg.)
	A	C		B	K	L		
CTM12513	12	13	79	4	80	33	3	20
CTM15020	5	0	89	0	10	5	2	35,
CTM15030	15	20	89	5	2	43	4	5
CTM17530	0	0	97	2	10	0	3	40
CTM20030	15	30	10	5	2	53	4	58
CTM20040	0	0	0	2	12	0	3	73
	17	30	10	6	0	56	4	81

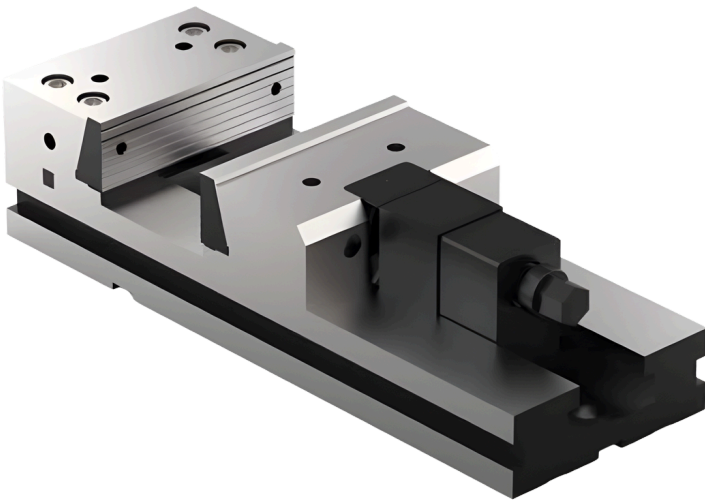
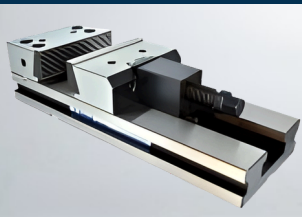

Precision Machinery Vice

Precision Machinery Vices Hard Jaws TYPE 1500

Order Code	Dimensions					Weight (Kg.)
	L	L1	L2	L3	M	
CT0126	12	34,	1	85	M5	1,5
CT0151	5	5	7	95	M5	2
CT0176	15	44	2	10	M6	3
CT0201	0	50	2	5	M6	3,5



Precision Machinery Vices Hard Jaws TYPE 1850

Order Code	Dimensions							Weight (Kg.)
	L	L1	L2	L3	L4	L5	M	
CT0132	12	34,	1	85	3	3	M5	1,5
CT0157	5	5	7	95	3	3	M5	2
CT0182	15	44	2	10	3	3	M6	3
CT0207	0	50	2	5	3	3	M6	3,5



Precision Machinery Vices Hard Jaws TYPE 1250

Order Code	Dimensions							Weight (Kg.)
	L	L1	L2	L3	L4	L5	M	
CT0130	12	34,	1	85	3	3	M5	1,5
CT0155	5	5	7	95	3	3	M5	2
CT0180	15	44	2	10	3	3	M6	2,5
CT0205	0	50	2	5	3	3	M6	3,5



Precision Machinery Vice Spare Parts

